

New!
MiracleAir™

High Performance HEPA-Type
Air Cleaner

**Remove
the smoke
not the smoker!**

**Ideal
For Cigar
Lounges!**

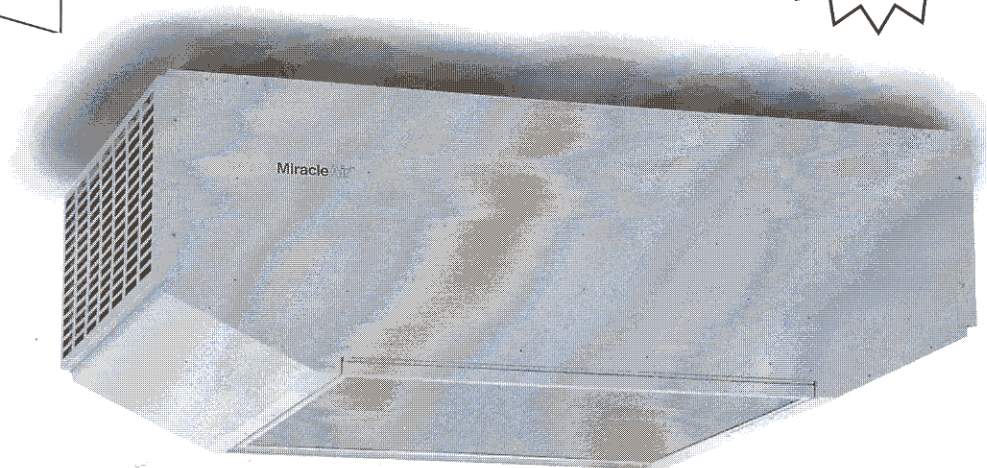

MiracleAir model CM-12 is the ultimate solution for indoor air pollution capturing both particulate and gaseous contaminants. Odors, tobacco smoke, pollen, dust, vapors and many other irritants are removed by high efficiency, long lasting disposable filters.

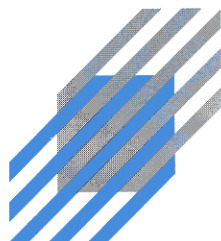

**AIR QUALITY
ENGINEERING**

Manufacturer and Worldwide Distributor of Air Cleaning Systems for Over 25 Years

MIRACLE AIR™ FEATURES & SPECIFICATIONS

"...indoor air is often two-to-five times more polluted than outdoor air and can be up to 1,000 times as dirty. The EPA estimates that most Americans are exposed every day to indoor air contaminants that can lead to serious health problems for some people, including cancer, respiratory ailments, fatigue and headaches."

Congressional Quarterly

Indoor Air Pollution Is A Big Problem...Now, There Is An Easy Solution!

The new Miracle Air is a comprehensive, state of the art filtration system which addresses odor, vapor and particulate for assured indoor air quality.

FEATURES & BENEFITS

- Removes dust, smoke, pollen other particles using high efficiency disposable filters.
- Removes odors and vapor contaminants with large twin odor/V.O.C. filters.
- Alleviate symptoms of Sick Building Syndrome.
- The solid state, variable speed controller allows for easy adjustments to air flow.
- 95% efficient @ .3 micron. HEPA type filter.
- Effective COANDA airflow gently and evenly distributes clean air and returns dirty air to the unit. COANDA air flow destratifies air and eliminates "stuffy" air pockets. (Shown right.)
- Low maintenance and long filter life is achieved because of the large volume of media used in both the particulate and the odor/V.O.C. disposable filters.
- Surface-mounted, self-contained media air cleaner designed for easy installation on any ceiling surface.

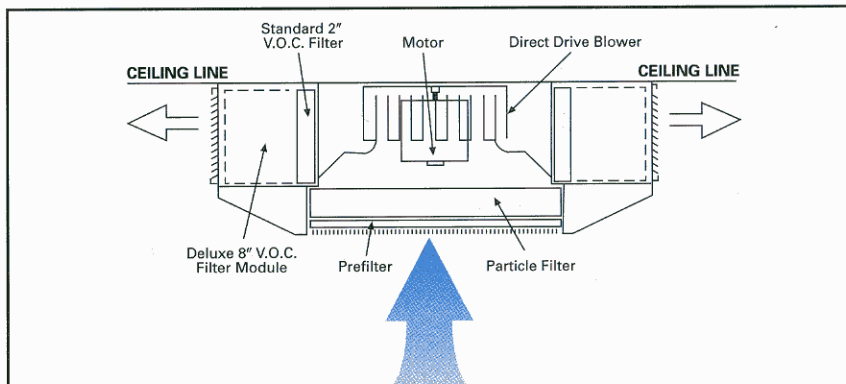

SPECIFICATIONS/MODEL CM-12

- CABINET:** Galvanized steel construction with attractive and durable autumn white powder coat finish.
- ELECTRICAL:** 115 Vac , 6.5 Amps, 60 Hz
- AIR VOLUME:** 850 CFM Maximum Speed
650 CFM High Speed
- PARTICLE FILTER:** 95% D.O.P. @ .3u HEPA type filter. 100 sq. ft. of filter media.
- PREFILTER:** 1/2" aluminum mesh. Part number 41194.
- ODOR/V.O.C. FILTER:** **Standard Model** includes two disposable activated carbon filters. 5 lbs. total activated carbon media.
Deluxe Model includes two VOC filter modules containing a total of 22 lbs. of adsorbent media blend. (80% activated carbon and 20% potassium permanganate.)
- SOUND LEVELS:** 69 dBA High Speed @ 6'
51 dBA Low Speed @ 6'
- DIMENSIONS:** Length 39", Width 22 5/8", Height 13 1/4"
- WEIGHT:** **Standard Model** 115 lbs. shipping
90 lbs. installed
Deluxe Model 149 lbs. shipping
124 lbs. installed
- MOTOR:** 1/2 horse power, PSC with sealed bearings.
- BLOWER WHEEL:** Forward curved, direct drive, 12 1/2" x 4" single inlet wheel.
- OPTIONS:** Remote variable blower speed control.

High Efficiency
Quiet Operation
Low Maintenance
MiracleAir™

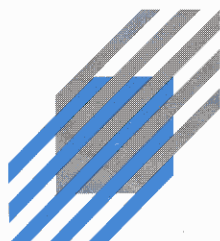
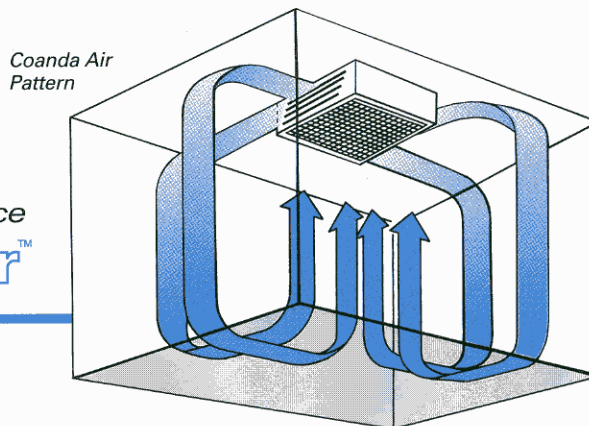

AIR QUALITY
ENGINEERING

7140 Northland Drive North, Brooklyn Park, MN 55428-1520 USA

FAX: (763) 531-9900 **EMAIL:** aqe@isd.net **WEB SITE:** www.air-quality-eng.com

TOLL FREE: 1-800-328-0787

Air Quality Engineering, Inc., has a policy of continuing product improvement, and reserves the right to make changes in design and specification without notice.