

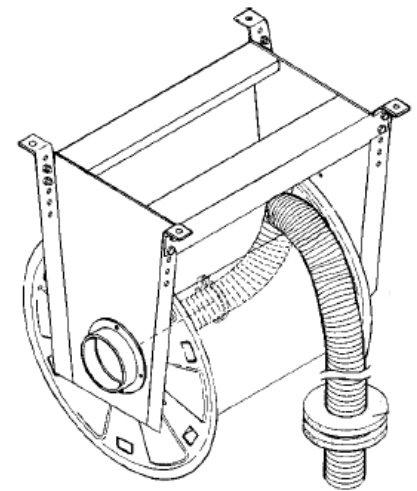

VEHICLE EXHAUST CASE STUDY *PNEUMATIC HOSE REEL SOLUTION*

Dave required a system that could universally fit all size tailpipes without damaging chrome finishes. The system also needed to be effective to capturing exhaust from vehicles under high RPM's. The last requirement was that it needed to be user friendly and out of the way when not in use.



The solution was a PlymoVent spring operated hose reel with a pneumatic Grabber® nozzle. The Grabber® inflates with air sealing the boot around the tailpipe. The soft high temperature Nomex lining provided a durable solution to protecting the chrome finished pipes.

The hose reel provided a means of storage to keep the system stored overhead and out of the way.

For more information on designing a vehicle exhaust system, or the hazards of diesel exhaust, contact Clean Air Company today.



428 NEW BRUNSWICK AVENUE, FORDS, NJ 08863

800-738-0911

WWW.CLEANAIRCO.COM